

INDUSTRIAL THERMOCOUPLES

Base Metal Thermocouple, Ceramic Protection Tube & Terminal Block Assembly

Model Code: **S2**

Operating Temperature:
+1000 C Max.

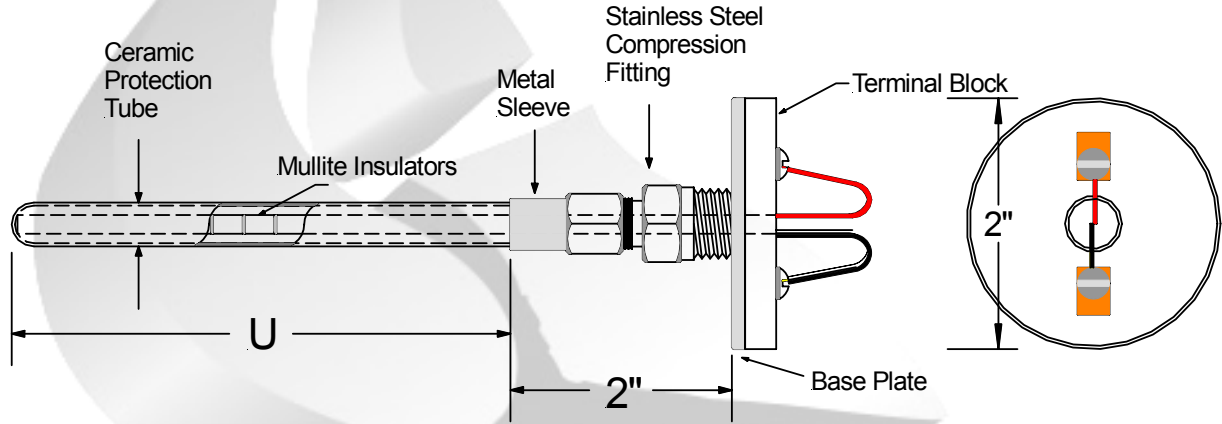

Model: **S2** — —

A	Ceramic Tube Size
A	1/4" O.D.
B	3/8" O.D.

B	Protection Tube
1	Alumina 1800C Max.
2	Mullite 1600C Max.

C	"U" Dimension
Specify "U" Length In Inches <u>06</u>	
Example "U" is 6" = 06	

D	Calibration	
	Standard Limits of Error	Special Limits of Error
A	J	C
B	K	D

E	Wire Size	
Gage	Single	Dual
20	1	4
24	2	5

F	Terminal Block Description
A	Ceramic
B	Ceramic, Spring Loaded
C	Plastic, 1" Dia. Micro Head Size

Nordic Sensors Ind. Inc. Tel: 1-888-667-3421 & Fax: 1-888-867-9986.