

Mineral Insulated Thermocouple & Thermowell Assembly

Nipple-Union-Nipple-Thermowell Style

Operating Temperature:
-200 C to +1000 C Max.

Model Code: **P4**

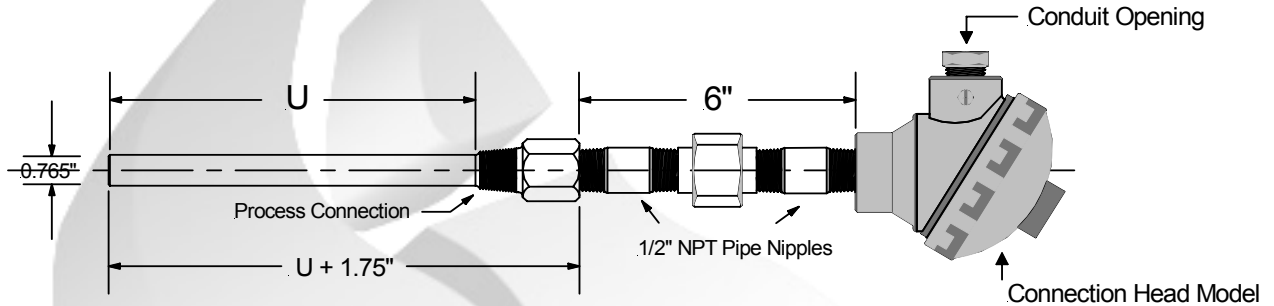

All Thermowell Assemblies Are Spring Loaded.

Model: **P4**

Model:	A	B	C	—	D	E	—	F	G	H	I
A Thermowell Type	1 Stepped	2 Straight	3 Tapered								
B "U" Fractional Dimension	A 1 5/8"	B 2 1/2"	C 4 1/2"	D 7 1/2"	E 10 1/2"	F 13 1/2"	G 16 1/2"	H 22 1/2"			
C Sheath Material	1 304 Stainless	2 316 Stainless	3 Inconel 600	4 Carbon Steel	5 Solid Teflon	For all other materials contact factory for availability.					
D Calibration	Standard Limits of Error		Special Limits of Error								
	1 J	2 K	3 T	4 E	5 N	6 J	7 K	8 T	9 E	10 N	
E Junction Styles	Element Description		Grounded		Ungrounded						
			Common	Common	Common	Isolated					
	Single		G			U					
	Duplex		D		F	H					
	Triplex		T		Q	R					
F Process Connection	1 1/2" NPT	2 3/4" NPT	3 1" NPT								
G Connection Head Model	A None, 3" Split Leads	B Cast Aluminum: Standard	C Cast Aluminum: Mini	D Polypropylene: FDA Appr.	E Cast Iron: Standard	F 316 Stainless Steel	G Explosion Proof				
H Conduit Opening	1 None	2 1/2" NPT	3 3/4" NPT								
I Connection Head Options	N None	B No Terminal Block	T 4-20mA Transmitter								

For all other U lengths contact factory for availability.

Nordic Sensors Ind. Inc. Tel: 1-888-667-3421 & Fax: 1-888-867-9986.